

160-1520 Solder terminal, turreted, feed thru

Recommended mounting hole .118 (3,00)

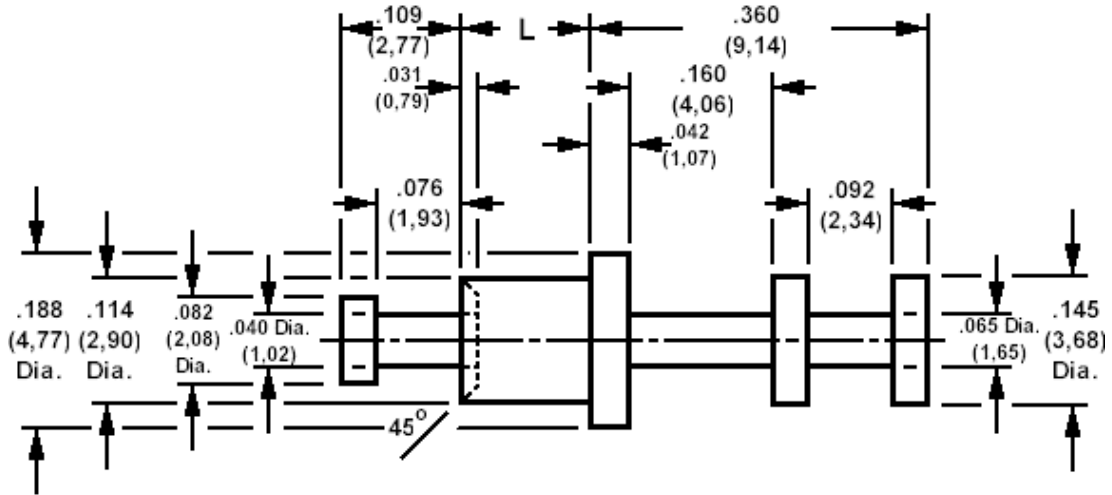

How to order code

160-1520-XX-YY-00

Basic Part No XX = L dimension, YY = Plating Finish

DIMENSIONS (XX)			
Basic Part No	(XX)	L	Board Thickness
160-1520	-02	.105 (2,67)	.062 (1,59)
	-03	.135 (3,43)	.094 (2,38)
	-04	.165 (4,19)	.125 (3,18)

MATERIALS			
Component	Material	Finish (YY)	
		-01	-05
Terminal	Brass	Silver	Electro Solder

SWAGE TOOLING	
Recommended Swaging Tools:-	
Anvil	435-6401-01-00-00
Roll punch	435-6623-01-00-00